

EQUIPPING FLASH WITH A MTCA.4-BASED LLRF SYSTEM

J. Branlard*, V. Ayvazyan, L. Butkowski, M. Grecki, M. Hoffmann, F. Ludwig, U. Mavrič, S. Pfeiffer, H. Schlarb, C. Schmidt, H. Weddig, DESY, Hamburg, Germany
K. Czuba, I. Rutkowski, D. Sikora, Ł. Zembala, M. Żukociński, ISE, Warszawa, Poland
W. Cichalewski, D. Makowski, A. Piotrowski, K. Przygoda, DMCS, Łódź, Poland
M. Kudła, NCBJ, Świerk, Poland, K. Oliwa, W. Wierba, IFJ PAN, Kraków, Poland

Abstract

The Free-Electron Laser in Hamburg (FLASH) is now equipped with a microTCA-based (MTCA.4) low-level radio frequency (LLRF) system, to replace the previous VME system and to serve as a test bench for the European X-ray Free Electron Laser (XFEL) LLRF system. This paper presents details on the new FLASH LLRF system setup, including installations inside the radiation prone tunnel environment. The benefits and preliminary results of the newly installed system are also given.

INTRODUCTION

FLASH is a soft X-ray free-electron laser (FEL) available to the photon science user community since 2005, producing X-ray pulses as short as 50 fsec. Its superconducting accelerator section provides a range of electron energies between 0.37 and 1.25 GeV, covering wavelengths from 45 down to 4 nm [1]. The accelerator comprises a normal conduction RF gun, a first 8-cavity cryomodule ACC1, a third harmonic module ACC39, a bunch compressor BC, a second accelerating RF station (ACC23), a second BC, and another two RF stations, namely, ACC45 and ACC67, as depicted in Fig. 2. The goal of the LLRF system is to control the accelerating gradient in amplitude and phase for each RF station, based on the vector sum control of cavity gradients [2].

Since 2005, RF stations are equipped with a VME standard digital feedback LLRF system. There were several motivations to replace the aging LLRF electronics with the MTCA.4-based LLRF system: the new system provides faster controls, higher resolution and bandwidth, and integration with other machine subsystems such as timing and synchronization, machine protection system (MPS) and beam diagnostics. Furthermore, the new MTCA.4 LLRF system is a prototype for the XFEL; its installation at FLASH provides extremely valuable experience with regards to its implementation in a large scale superconducting accelerator. In particular, the choice of placing the LLRF control electronics under the cryomodules for selected RF stations (RF gun, ACC1, ACC39 and ACC23) is essential to understand the environmental conditions for the LLRF system, which will also be installed inside the XFEL tunnel. The photos of Fig. 1 show the 16U racks located underneath the cryomodules ACC1 (top) and ACC3 (bottom) at FLASH. A special boron radiation shielding

was design to protect the racks and the electronics. Most of the radiation is expected to come along the beam line, justifying the protection above and on the sides of the racks. Unlike for ACC1, the racks under ACC3 were purposely not equipped with radiation proof front doors, to evaluate their necessity and efficiency.



Figure 1: Injector racks at ACC1 (up) and ACC23 (down).

THE MTCA.4 LLRF SYSTEM

The LLRF system is organized around the MicroTCA.4 (MTCA.4) crate. Fig. 3 shows the block diagram of the main LLRF components for an RF station. The MTCA.4 crate is equipped for 2 cryomodules (for example, ACC2 and ACC3). It comprises six pairs of down-converters (uDWC) digitizers (uADC), and one pair of controller (uTC) vector modulator (uVM). Also shown are the MTCA.4 crate backbone modules: the CPU running the front-end LLRF controller server, the management controller hub (MCH) and two power entry modules (uPM).

* julien.branlard@desy.de

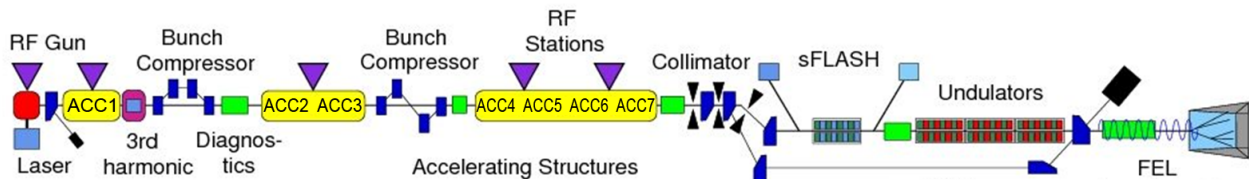

Figure 2: FLASH accelerator overview. The first RF station consists of one cromodule, ACC1, the other three RF stations are all organized as one klystron for two cryomodules: ACC23, ACC45 and ACC67.

Each MTCA.4 LLRF crate also hosts one timing module (x2timer) and one machine protection system (MPS), communicating with the other modules over the AMC backplane. For each cryomodule, one uDWC-uADC pair is dedicated to cavity probes (PRB), one to forward (PFW) and one to reflected (PREF) power signals. Also shown in Fig. 3 are the external supporting modules. These are responsible for piezo measurements and control (PZ16M), reference synchronization (REFM), drift calibration of RF signals (DCM), generation and distribution of clocks and local oscillator signals (LOGM), and power supply distribution (PSM). Details about the functionality of these different modules are found in [3] and [4], details on the application firmware for the main MTCA.4 boards are presented in [5].

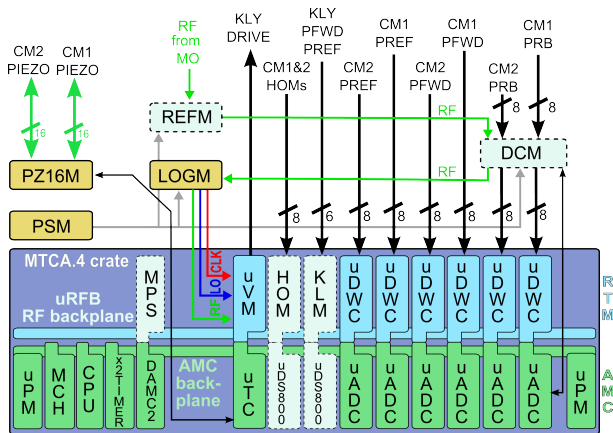

Figure 3: MTCA.4 LLRF main components overview.

The light-color and dashed-lines indicate that the corresponding modules were not installed during the recent FLASH shutdown but will be installed during the next maintenance time, toward the end of 2013. This applies for the REFm and the DCM, but also for the direct sampling digitizers (uDS800) and their paired modules dedicated to higher order modes (HOMs) diagnostics and to the klystron lifetime monitoring (KLM) system. The new machine protection system (MPS), prototype for the XFEL will also be installed at a later stage.

Except for piezo, all cavity signals (PRB, PFW, PREF) are going to a patch panel with 2-way RF splitters: one branch is connected to the old VME system while the other to the MTCA.4 system. Although this approach introduces

a point of failure, potential phase drifts and cross talks, the net benefits are two fold: first it leaves the VME system as a temporary backup solution, and second, it provides an independent monitoring system to perform out-of-loop control performance measurements.

The MTCA.4 crate configuration for the RF stations ACC23, ACC45 and ACC67 follows the layout of Fig. 3, as shown in the picture of Fig. 4. The first accelerating module (ACC1) and the third harmonic cryomodule (ACC39) constitute a special case as each RF module has its own klystron. However, the crate occupation for this special case is handled in a similar fashion, with the difference that two slots are allocated for a uTC-uVM pair, each driving a separate klystron. The CPU runs two independent front-end servers, one for each cryomodule. From a controls perspective, these two systems behave as two independent stations, although hosted into a single crate.

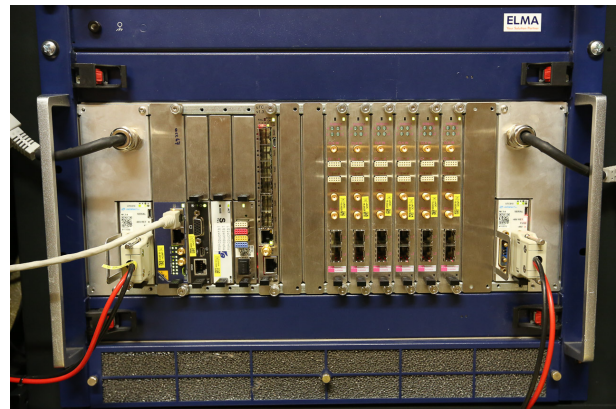

Figure 4: MTCA.4 crate installed at FLASH, hosting the LLRF system for one RF station (i.e. two cryomodules).

Although not shown on this picture, beam diagnostic electronics were also integrated and installed into an MTCA.4 crate. These boards installed in ACC1, ACC23 and ACC45 LLRF racks gather signals from the toroid and bunch compression monitors, and are used for beam loading compensation and beam-based feedback [6]. All MTCA.4 crates are hosted into water-cooled racks, the inlet air temperature is set to 18°C.

OPERATION

Along with the new hardware installation, the LLRF firmware and software were upgraded. All functional-

ties of the VME system were converted to the MTCA.4 system, and new features were added. Among the existing functionalities, one could cite beam loading compensation, controller output correction, adaptive feedforward, and MIMO feedback controller [7]. The implementation of $8\pi/9$ notch filters on all cavity probe channels is among the new features of the MTCA.4 recently commissioned. The plot of Fig. 5 illustrates another benefit of the new LLRF system. The higher resolution ADCs and the higher data processing speed (9.027 MHz instead of 1 MHz) provide a high-accuracy field detection. Fig. 5 shows the amplitude of the 16-cavity vector sum gradient loaded by single 1.3 nC bunches as a function of time. The high-resolution field detectors allow to detect a single bunch transient. The delay of individual cavity channels can thus be accurately adjusted until all cavity transients are aligned in time, resulting in the clear vector sum transients shown in Fig. 5.

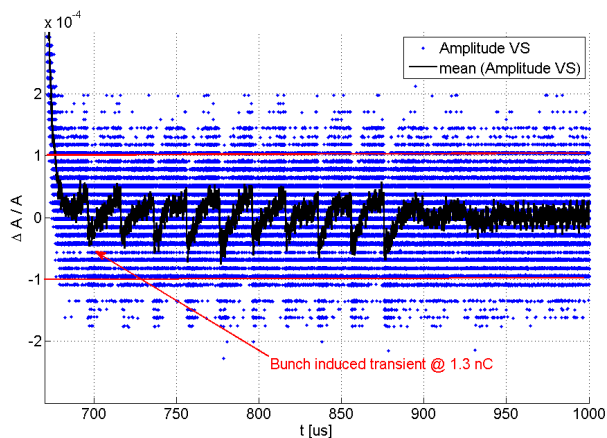

Figure 5: Uncompensated single bunch beam loading on the vector sum gradient amplitude.

With the exception of the RF gun, FLASH is now fully controlled by the MTCA.4 LLRF system. Commissioning is still underway; user studies are to resume in October 2013. Preliminary performance results obtained with the prototype MTCA.4 LLRF system previously installed for ACC1 have already been reported in [4] and [8]. The novelty of this installation will be gaining experience with the entire accelerator operated with MTCA.4 and understanding how the performance of the MTCA.4 system scales to a machine as large as the XFEL.

Numerous automation servers were developed for the VME-based LLRF system [9] and still need to be adapted to the new LLRF system. These include automatic Lorentz force detuning compensation using piezo tuners, cavity quench detection and protection, automatic monitoring and adjustments of the cavities loaded quality factors, or finite state machine for RF station ramp-up and shutting off sequence. The MTCA.4 LLRF also brings new opportunities for high-level server development. An overall energy server to monitor and redistribute the energy among RF stations when one operates lower than expected (due to cav-

ity quenches or unexpected performance losses). To this extend, optical fibers were installed, connecting in a daisy chain MTCA.4 LLRF controllers from neighboring RF stations.

Another imminent upgrade of FLASH is the recent construction of a second undulator line, FLASH II [10]. From a LLRF point of view, this brings interesting challenges, as various bunch trains with different acceleration amplitude and phase requirements are now controlled within the same RF pulse. The new MTCA.4 system combined with the new MTCA.4 timing module (x2timer) is designed to handle multiple beam patterns. This complex beam acceleration scheme is a prototype for the multiple beam line XFEL. The commissioning of FLASH II is scheduled to start before the end of 2013.

CONCLUSIONS

All RF stations at FLASH, with the exception of the RF gun, are now controlled by the new MTCA.4-based LLRF system. Some of these systems were installed into the accelerator tunnel to gain experience in view of the XFEL LLRF installations. Fast optical communication between adjacent RF stations also serves as a test bench for high-speed and high-level controls algorithms on a machine-scale level. Currently, only the standard LLRF modules were installed, with place holders and cabling reserved for the full system upgrade scheduled for the end of this year. This will include modules to compensate for phase and amplitude drifts (DCM) and modules for RF reference signal synchronization (REFM). Future FLASH upgrades will also cover the new MTCA.4 design of beam arrival time monitors, and the MTCA.4 implementation of the LLRF clock and local oscillator generation module.

REFERENCES

- [1] <http://flash.desy.de>
- [2] T. Schilcher, “Vector Sum Control of Pulsed Accelerating Fields in Lorentz Force Detuned Superconducting Cavities”, PhD Dissertation, DESY Hamburg, Germany, 1998.
- [3] J. Branlard *et al.*, “The European XFEL LLRF System”, Linac 2012, MOOAC01, New Orleans, USA.
- [4] C. Schmidt *et al.*, “Recent Developments of the European XFEL LLRF System”, IPAC 2013, Shanghai, China.
- [5] J. Branlard *et al.*, “MTCA.4 LLRF System for the European XFEL”, MIXDES 2013, Gdansk, Poland.
- [6] S. Pfeiffer *et al.*, Fast Feedback Strategies for Longitudinal Beam Stabilization, IPAC 2012, New Orleans, USA.
- [7] C. Schmidt *et al.*, Parameter estimation and tuning of a multivariable RF controller with FPGA technique for FLASH, American Control Conference 2008.
- [8] C. Schmidt, “Precision regulation of radio frequency fields at FLASH”, LLRF Workshop 2011, Hamburg, Germany.
- [9] J. Branlard *et al.*, LLRF Automation for the 9mA ILC test at FLASH, LINAC 2012 Tel Aviv, Israel.
- [10] B. Faatz *et al.*, “FLASH II: a Seeded Future at FLASH”, IPAC 2010, Kyoto, Japan, 2010.