

# THE TRANSVERSE DAMPING SYSTEM WITH DSP PLL TUNE MEASUREMENT FOR HERA P

D. Heins, J. Klute, R.D. Kohaupt, K.H. Matthiesen, S. Pätzold, J. Rümmler  
 DESY, Hamburg, Germany

## Abstract

A new transverse feedback system has been installed and tested in the HERA proton ring. The system is an advanced version of the multibunch feedback systems in the DORIS, PETRA, and HERA electron rings. A new low-noise type of oscillation detector has been developed in order to provide better quality beam signals. Signal processing is performed through a three tap FIR-filter with 12 bit resolution at 10.4 MHz. The environment of the system is well suited to include a continuous PLL tune measurement (Detector, Kicker A/D and D/A converters). The possibility of processing a single bunch in parallel to the feedback path was added. In order to gain a narrow band beam transfer function, the feedback loop gain for this bunch can be reduced. The advantage of this method is that a pilot bunch can be used to measure the tune while damping the rest of the beam.

## 1 THE BASIC STRUCTURE OF THE SYSTEM

A block diagram of the main components of the system is shown in figure 1.

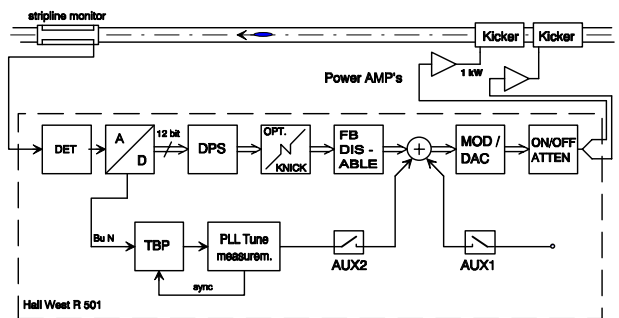

Figure: 1 Structure of one direction of the System.

A directional-coupler monitor [1] serves as the horizontal and vertical pick-up station.

The detector device (DET) demodulates the betatron oscillations from the pick-up signal. Great improvement was achieved by using a differential peak-detector with additional digital offset compensators.

After analog to digital conversion the detected displacement oscillation is fed into a Digital Phase Shifter (DPS). This phase shifter is an FIR (Finite Impulse Response) type filter that is able to shift the

phase of each bunch individually. Therefore it is clocked by the bunch repetition frequency 10.4 MHz. The phase angle is adjustable in 5 degree steps over a range of 360 degree. It is important that the delay time of the system is the same as the time that a bunch needs to travel from the monitor to the kicker in order that each bunch sees its own phase shifted oscillation signal. The digital phase shifter has the ability to adjust this delay time.

For tune measurement and test facilities the beam can be excited through an admixture of external signals with the digital oscillation signal. Moreover the oscillation signal can be attenuated or disabled for this purpose. This can be done for all or only a single bunch. A nonlinear transfer function (KNICK) may also be included. This produces small betatron oscillations.

Due to the lower cutoff frequency of the power amplifiers the base band of transverse displacements must be shifted to a frequency range between 5.2 MHz and 10.4 MHz. For this purpose a digital modulator has been applied. The phase and frequency shifted signal is then reconverted to analog and fed back to the beam. [2]

## 2 THE TRANSVERSE DETECTOR

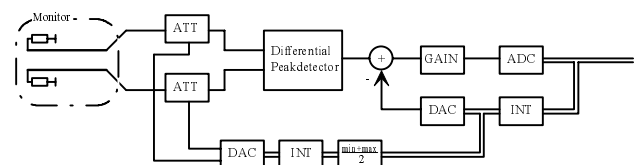

Figure: 2 Structure of the transverse detector.

In order to get the maximum dynamic range of the channel two nested digital control loops are applied. Independence of slow orbit deviations or a decentral beam passing through the monitor is reached through the outer loop that controls two pin-diode attenuators. This can be described as 'Total Offset Correction'. Signal offsets that may occur due to different currents of adjacent bunches are compensated through the inner loop which works much faster and generates a compensation individual for each bunch. This loop is called 'Individual Offset Compensation'. Figure 3 illustrates the behavior of the signals at the input of the ADC.

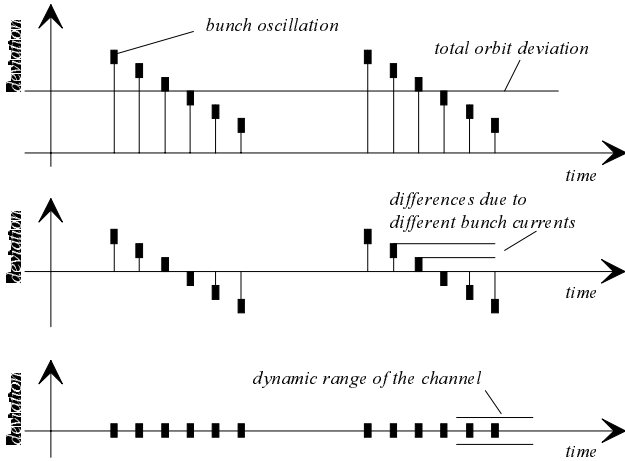

Figure: 3 above: The raw signal, middle: After Total Offset Correction, below: After Individual Offset Correction.

### 3 THE DIGITAL PHASE SHIFTER (DPS)

Principally the displacement information of a given bunch is calculated with the displacement information of its last two turns. The result must then be fed back to the same bunch. As already mentioned the delay time of the feedback system must be adjustable. Therefore a shift register that is configurable in length is placed at the entry of the DPS so that the delay time of the system can be easily adjusted.

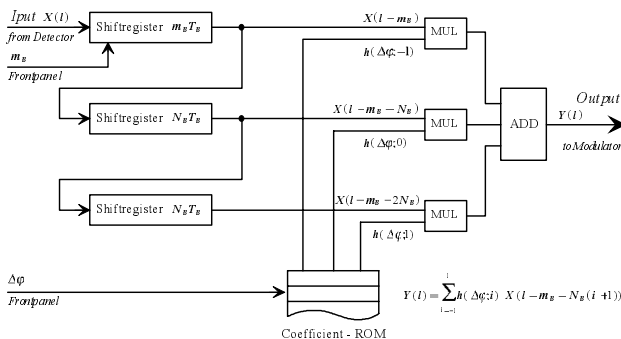

Figure: 4 Structure of the FIR-type digital phase shifter.

This first shift register is followed by two further shift registers. The number of memory locations of these two shift registers matches the number of bunches that can be stored in the machine.

At any given time the output of the three shift registers represents the actual information of a certain bunch and the information from its last two turns. The output of the filter is generated by multiplying these three values with a set of three coefficients and adding the results together.

There are 72 different sets of coefficients stored in this Coefficient-ROM. Therefore the filter is adjustable in 5 degree steps over a range of 360 degrees.

## 4 THE DIGITAL MODULATOR (MOD/DAC)

In order to shift the basebands of the transverse displacements to the frequency range of 5.2 MHz to 10.4 MHz, a digital modulator has been applied. Instead of using only a single digital word within the sampling time, the modulator produces an inverted word immediately after each digital word. At the output of the DAC and after passing a low-pass Butterworth filter, one obtains a 10.4 MHz signal instead of the dc-component. Accordingly the baseband is shifted into the range between 5.2 MHz and 10.4 MHz. In addition, fine delay adjustment within 96 nsec is provided by the unit.

## 5 DSP PLL TUNE MEASUREMENT

The damping effect of the Feedback system makes tune measurement more difficult because betatron oscillations cannot be observed through the conventional FFT analysis that works by excitation of a multibunch mode. On the other hand, excitation of the beam is necessary to measure the tune. In order to minimize disturbance during luminosity runs, a 'Phase Locked Loop' has been integrated into the Feedback system. This method excites only a single bunch, that can be a pilot bunch. The gain of the feedback system can be reduced only for this bunch, so the result is a transfer function that becomes a narrow resonance characteristic. Figure 4 shows the principle structure of the PLL tune measurement. The phase response of the beam transfer function crosses zero at the betatron resonance. This behavior can be used to vary the frequency of a numeric controlled oscillator in such a way that it follows tune shifts of the beam. In order to ensure constant amplitude for betatron oscillations a second loop has been added. It works by regulating the excitation intensity of the beam.

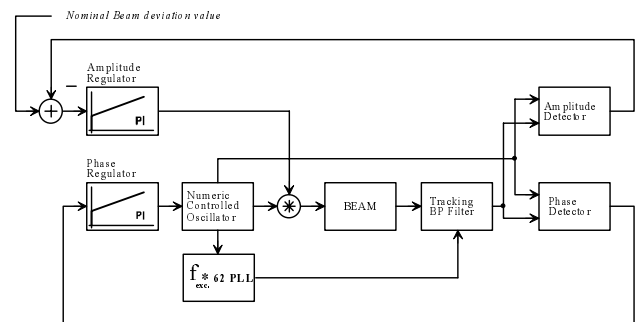

Figure: 5 Structure of the PLL tune measurement.

Sensibility can be considerably improved through the bandpass filter at the input of the device. Unwanted signals are suppressed as well. Since the bandpass must not produce any extra phase shifts, it was designed as a digital 'tracking bandpass'. Its clock frequency is provided through an additional PLL that produces a synchronous output that is 62 times higher than the

oscillator frequency. All components except those of the tracking filter are implemented in software on a PC DSP board for each direction. The PC is a 19" rack mounted type that is connected to the control system via NOVELL net.

## 6 RESULTS

The system has been successfully tested for both directions during the machine shifts before shut down time (Nov. 1995).

The sensitivity of the detector has been determined to less than 10  $\mu\text{m}$ . The damping time could be decreased by a factor of 240.

In order to measure the coherent damping time, the beam was excited through a continuous burst signal that is adjusted to the betatron resonance. By triggering an oscilloscope with the burst repetition rate one can observe the betatron oscillations. Figure 6 shows the damping time of the beam when the feedback loop is open. The rising edge of the lower trace denotes the end of excitation. The damping time is about 60 msec.

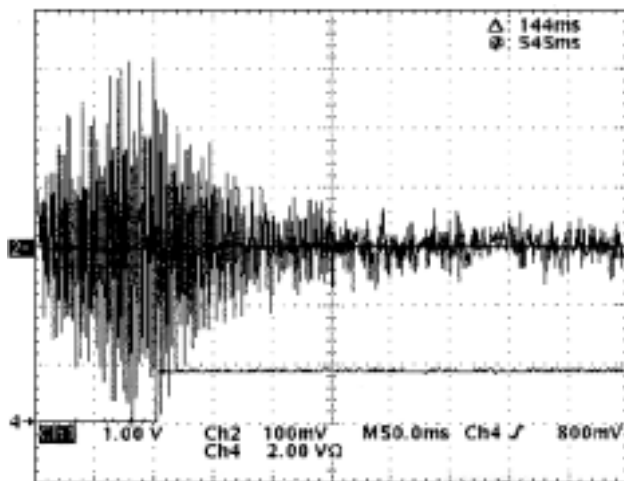

Figure 6 Horizontal damping time after burst excitation, Feedback Loop open, Hor. scale = 50msec/div  $\tau \approx 60$  ms.

Figure 7 shows the same as fig. 6 but the feedback loop was closed. Note that the horizontal scale has changed from 50 msec / div to 500  $\mu\text{sec}$  / div.

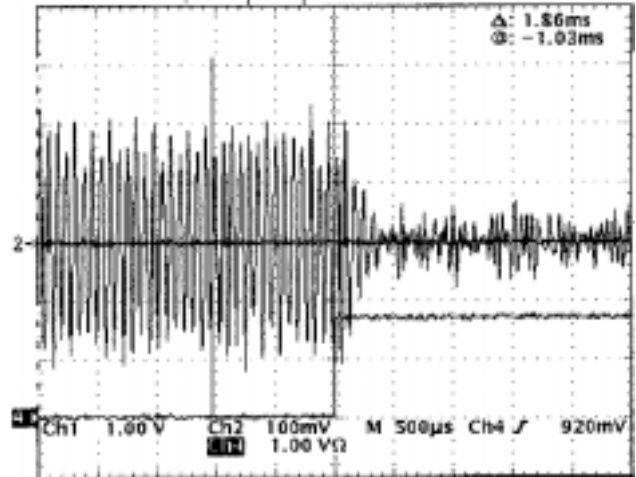

Figure 7 Horizontal damping time after burst excitation, Feedback Loop closed.

Hor. scale = 500  $\mu\text{sec}$ /div,  $\tau \approx 250$   $\mu\text{s}$ .

Figure 8 shows an FFT of the detector output. The tune measurement is locked at the horizontal and the vertical betatron resonances while the feedback system is active. The typical accuracy is  $4 \cdot 10^{-4}$ .

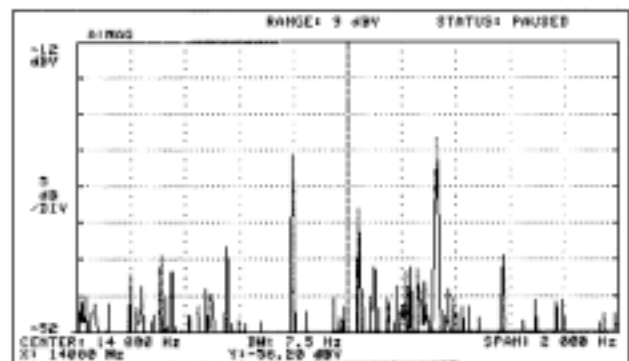

Figure 8 Horizontal and Vertical PLL running at  $Q_x=0.2917$ ; 13.8 kHz and  $Q_z=0.3027$ ; 14.32 kHz. SPAN 2 kHz; CENTER 14 kHz.

## REFERENCES

- [1] 'THE NEW DIRECTIONAL COUPLER PICKUP FOR THE HERA PROTON BEAM POSITION MONITORING SYSTEM.'  
By W. Schuette, M. Wendt, K.H. Mess (DESY), 1987. Hamburg Desy  
DESY HERA 87-08 (87,REC.MAY).
- [2] 'FEEDBACK KICKERS IN THE DESY RINGS.'  
By J. Ruemmler (DESY), 1994. Hamburg DESY Internal Rep. M-94-03-U (94/07,rec.Aug.) In London 1994, Proceedings, EPAC 94, vol. 2 1598-1600, and Hamburg DESY Int.Rep.M-94-03-U (94/07,rec.Aug.)